

**Nidec**

**Drives**

# Cables & connections

Servo series

Unimotor hd | Unimotor fm | Digitax HD | Unidrive M

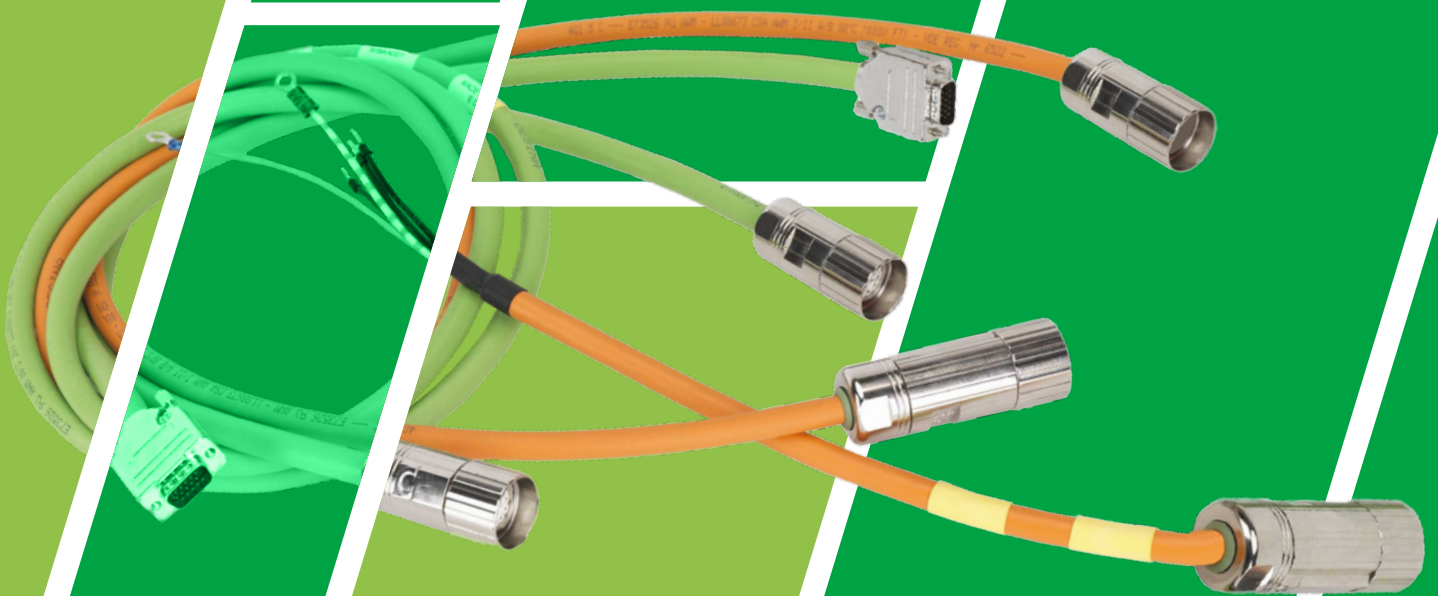

# Connectivity

Cables form an integral part of a servo system installation. The ready made cables from Nidec Drives allow system installers to avoid intricate, time consuming assembly normally associated with connecting servo systems.



## Reliability and safety

Nidec Drives maintains the highest standards of cable integrity and reliability in compliance with all regulatory requirements. All cables and connectors are constructed to meet safety standards and protected against EMC noise immunity, to ensure reliable and failsafe operation.



## Matched motor, drive and cable combinations

Our cables are designed to ensure optimum connection between Unidrive M or Digitax HD drives, and Unimotor fm or hd motors.



## Variants

Choosing the right cables and connections for your application is critical in getting optimum performance. Nidec Drives has an extensive range of options that can meet the requirements for different servo motor and drive combinations to suit most applications:

- Phase conductors from 1.0 mm<sup>2</sup> (10 A) to 25 mm<sup>2</sup> (70 A).
- With and without brake wire pairs.
- Motor end connector or ferrules for hybrid box.
- Drive end tailored to suit drive, i.e. ferrules or ring terminals.
- Hybrid option, combining both power and signal into one convenient cable.



## Wide range of accessories

In addition we offer a range of accessories to cover your system requirements:

- Feedback and power cables for static and dynamic applications
- Conversion cables
- Connector kits
- Flange kits



## Features

- Low-smoke, halogen-free and flame-retardant construction (PUR jacket type).
- Power cables and connectors UL recognised.
- Complies with DESINA coding - Orange for power, Green for signal.
- Optimum noise immunity.
- No need for crimp and insertion / removal tools.
- Encoder cable has low voltage drop for longer cable lengths and separately screened thermistor wires.
- Pre-assembled cables offer consistent quality at competitive prices.
- Power cables either with or without brake wires.
- Cable assembly type identification label.
- Brake wires are separately shielded within the power cable.



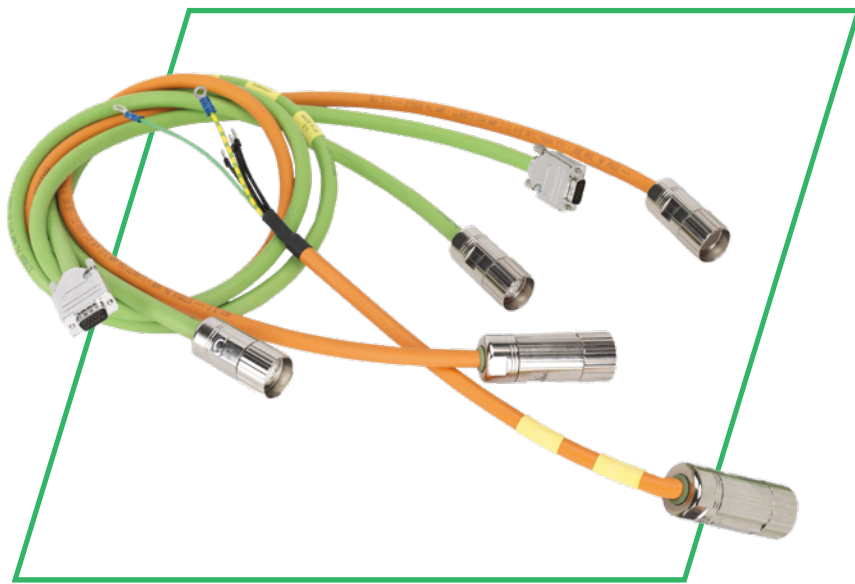

## Cable specifications

	Power	Signal
Jacket type	PUR	PUR
Electrical	Nominal voltage 1,000 V UL Maximum 350 V (VDE/DIN) Test voltage: maximum 3 kV Conductor resistance (at 20 °C): according to class 6 VDE 0295, EN60228 Insulation resistance (at 20 °C): > 20 MΩ x km Mutual capacitance: core / core approx. 70 pF/m core / screen approx. 110 pF/m Speed of propagation (Vp): 5.05 ns/m (66%)	
Mechanical	Minimum bending radius: 5 x outer diameter (fixed installation) Minimum bending radius: 7.5 x outer diameter (dynamic installation) Installation: cable into drag-chain Maximum speed: 5 m/s Maximum acceleration: 40 m/s <sup>2</sup> Number of cycles: 5,000,000	
Thermal	-40 °C to +80 °C (fixed) -25 °C to +80 °C (movement)	
Chemical	Oil resistance: according to EN 50363-10-2, OIL 80 °C UL 758	
Fire behaviour	Halogen-free: in accordance with IEC 60754-1	
Approvals	Desina standard - UL/CSA AWM EC Low voltage directive 73/23/EEC and CE marking directive 93/68/EEC EU directive 2002/95/CE restriction of the use of hazardous substance (RoHS)	

# Cables

## ordering information

### Power cable

Field number

1	2	3	4	5	6	7	8	9	10	11	12
M	B	B	A	A	A	0	0	2	5	0	1

Cable type (field N° 1 & 2)

**MB** = Power + 2w

**MS** = Power

**MQ** = Power + 2 x (2w) (\*\*)

Jacket type (field N° 3)

**B** = PUR dynamic installationn

Length metre (\*) field N°7, 8, 9 & 10

**0010** = 1 m

**0025** = 2.5 m

**1000** = 100 m max

**Optional:**  
Progressive alphanumeric code for customer special requests (field N° 11 & 12)

Phase & conductor size (field N° 4)		Drive end connection (field N° 5)	Motor end connection (field N° 6)
<b>MS</b> = Power	<b>MB/MQ</b> = Additional Parts	<b>A</b> = Unidrive M size 3-4-5, Digitax HD/ST, Flying Leads (Ultrasonic Welding)	<b>A</b> = 6 way power size 1, from 1 to 2.5 mm <sup>2</sup>
<b>A</b> = 1 mm <sup>2</sup>	+ 0.5 mm <sup>2</sup>	<b>B</b> = Unidrive M size 6,	<b>B</b> = 6 way power size 1.5, 4 mm <sup>2</sup>
<b>B</b> = 2.5 mm <sup>2</sup>	+ 0.5 mm <sup>2</sup>	<b>C</b> = Unidrive M size 7	<b>C</b> = 6 way power size 1.5, from 6 to 10 mm <sup>2</sup>
<b>C</b> = 4 mm <sup>2</sup>	+ 1 mm <sup>2</sup>	<b>D</b> = Unidrive M size 8	<b>D</b> = Hybrid box ring terminal M6
<b>D</b> = 6 mm <sup>2</sup>	+ 1 mm <sup>2</sup>	<b>P</b> = Motor power 6 way extension	<b>E</b> = Hybrid box ring terminal M8
<b>E</b> = 10 mm <sup>2</sup>	+ 1 mm <sup>2</sup>	<b>X</b> = Cut end	<b>F</b> = Ferrules
<b>F</b> = 16 mm <sup>2</sup>	+ 1 mm <sup>2</sup>		<b>M</b> = 8 way YTec
<b>G</b> = 25 mm <sup>2</sup>	+ 1 mm <sup>2</sup>		<b>X</b> = Cut end



(\*) Length metre / cable requiring (cm) lengths will be rounded up to the next highest half metre; e.g. 2.1 will be changed to a 2.5 m cable.  
Maximum cable assembly length 100 m.  
For hybrid box wiring diagram please refer to page 16.  
\*\* MQ cable is for O60 Frame motors only.

# Signal cable

Field number

1	2	3	4	5	6	7	8	9	10	11	12
S	I	B	A	A	A	0	0	2	5	0	1

\*Jacket type (field N° 3)

B = PUR dynamic installation

Length metre (\*\*) (field N°s 7-10)

0010 = 1 m

0025 = 2.5 m

1000 = 100 m max



Optional:

Progressive alphanumeric code for customer special requests (field N° 11 & 12).

Cable & Jacket type, Phase & conductor size (field N°s 1, 2 & 4)	Drive end connection (field N° 5)	Motor end connection (field N° 6)
SI*A = SI - (Incremental encoder + SinCos EnDat 2.1)	A = Unidrive M700, Digitax ST (Encoder 15 pin D type straight connector)	A = Unimotor 17 way connector (SI/SE)
SR*B = SR - (Resolver)	B = Unidrive M700 Resolver/Sincos ferrules	B = Unimotor 12 way connector (SR/SS)
SS*C = SS - (Sincos Hiperface Encoder)	F = Unidrive M750 (Digitax HD) Encoder 15 Pin D type 90 Deg connector HD	D = Unimotor 90° 12 way connector (SR/SS)
SE*E = SE - (Serial EnDat 2.2 BiSS-C)	G = Digitax HD, low profile 90° - inc. SC EnDat, Resolver & SinCos (15 pin D type) with flying lead for thermistor	G = Unidrive M / Unidrive SP / Digitax ST (Encoder 15 pin D type connector hd ) Extension
	P = Signal male plug Extension	K = Unimotor 15 way YTec connector
	T = Digitax HD (M750) low profile 90° - EnDat 2.2 only (Encoder 15 pin D type connector)	L = Unimotor 12 way YTec connector
	X = Cut end	X = Cut end

Cable	Feedback option
SI	CR, CA, CT, EM, FM, EC, FC, EB, FB
SR	AR, AE
SS	TL, UL, RA, SA
SE	EF, FF, EG, FG, GB, HB, EN, FN

Encoder breakout kits for use with 'B', Flying leads drive end connection

Part Number	MK Description	Image
82700000020200	Encoder breakout kit for Digitax HD	
82000000012200	Encoder breakout kit for Unidrive M70x	

e.g. 067UDB300BACRA would require a SIBAF0050 cable part number.

(\*\*) Length metre / cable requiring (cm) lengths will be rounded up to the next highest half metre; e.g. 2.1 will be changed to a 2.5 m cable. Maximum cable assembly length, please refer to page 17. For complete cable construction, please refer to page 9.

## EnDat 2.2 Hybrid (Power and signal combined)

Field number

1	2	3	4	5	6	7	8	9	10	11	12
H	Y	B	A	A	A	0	0	2	5	0	1

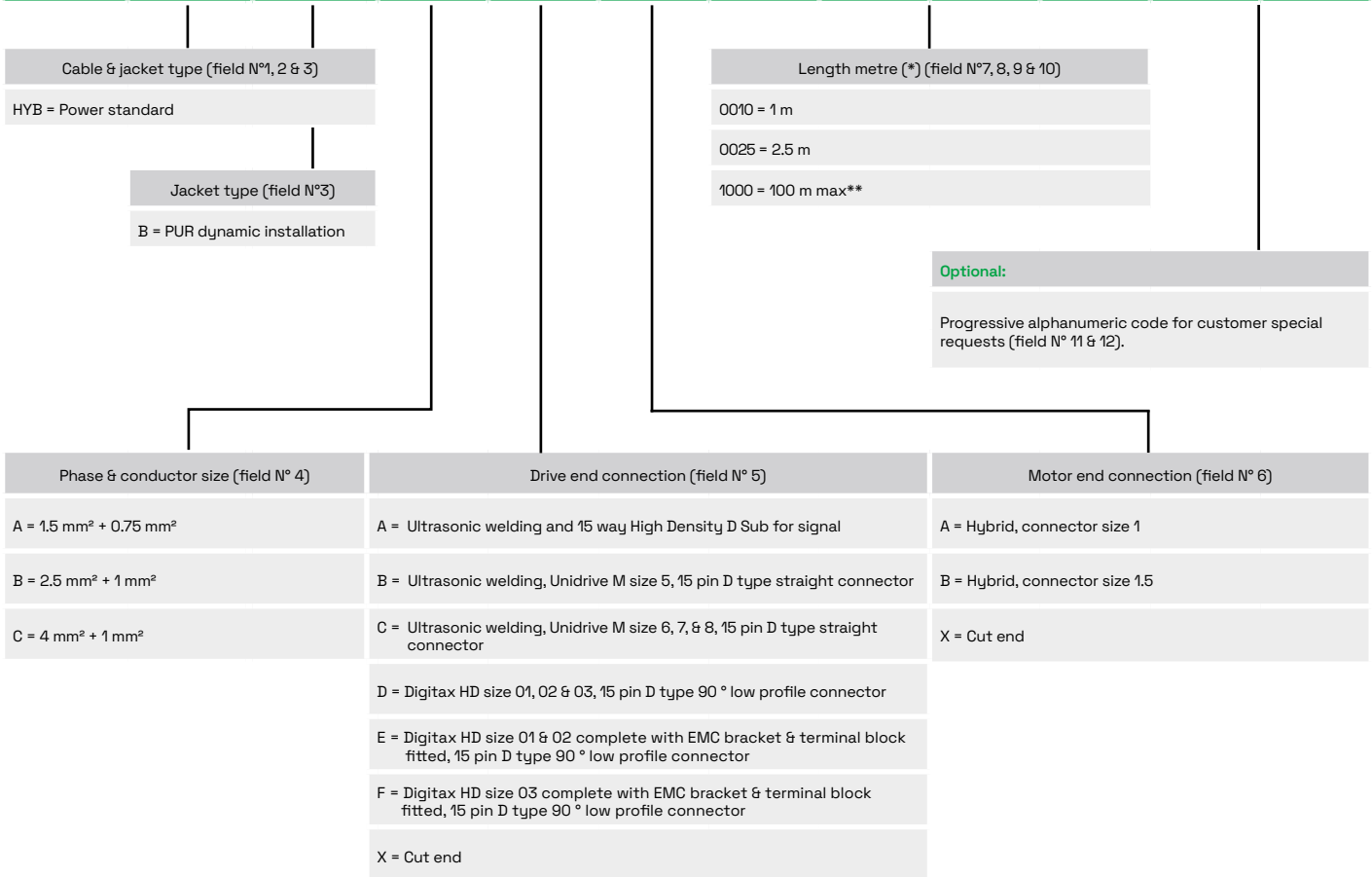

## EnDat 3 Hybrid (Power and signal combined)

1	2	3	4	5	6	7	8	9	10
H	Q	B	A	A	A	0	0	2	5

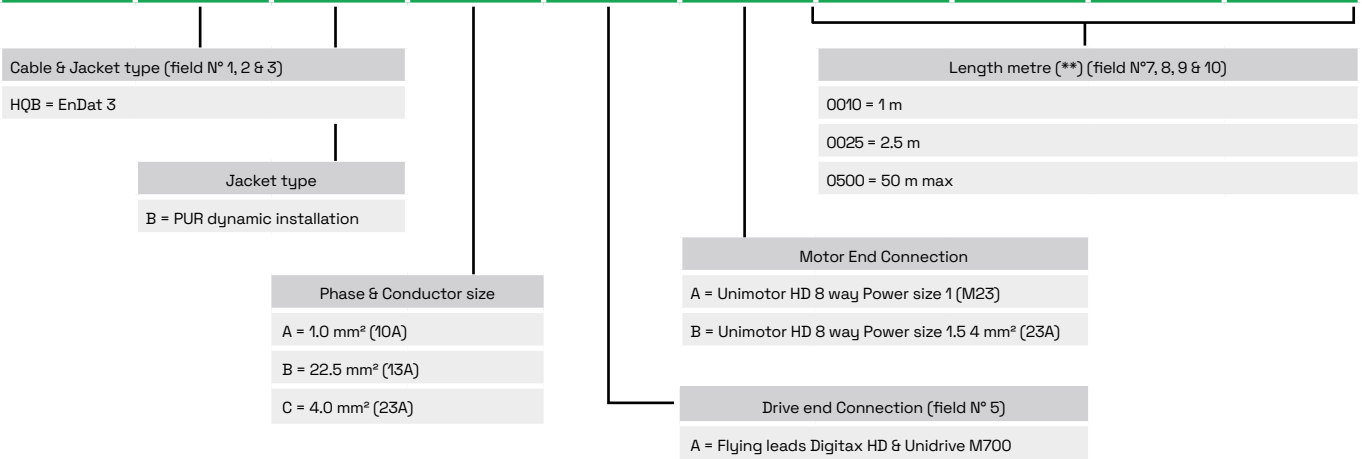

(\*) Length metre / cable requiring (cm) lengths will be rounded up to the next highest half metre; e.g. 2.1 will be changed to a 2.5 m cable. Maximum cable assembly length please refer to page 17.  
 \*\* For Digitax HD maximum cable length is 50 m.

# Cable construction

## Power cable

Phase and conductor size (current rating CEI EN 60204-1:2006-09 at 40 °C - installation method B2)	Power + number of cores x cross section (mm <sup>2</sup> )	Nominal outer diameter (mm) MS	Nominal outer diameter (mm) MB	Tolerance (mm)
1 mm <sup>2</sup> (10.1 A)	4G1 + (2 x 0.5)	8.1	9.9	± 0.3
MQ = 1 mm <sup>2</sup> (10.1 A)	4G1 + 2 x (2 x 0.5)			
2.5 mm <sup>2</sup> (7.4 A)	4G2.5 + (2 x 0.5)	10.9	12.5	± 0.3
4 mm <sup>2</sup> (23 A)	4G4 + (2 x 1)	12.1	12.5	± 0.3
6 mm <sup>2</sup> (30 A)	4G6 + (2 x 1)	14.8	16.2	± 0.4
10 mm <sup>2</sup> (40 A)	4G10 + (2 x 1)	18.3	19.5	± 0.4
16mm <sup>2</sup> (54 A)	4G16 + (2 x 1)	21.4	21.6	± 0.5
25 mm <sup>2</sup> (70 A)	4G25 + (2 x 1)	26.5	26.9	± 0.5

## Signal cable

Cable code and type	Construction cross section (mm <sup>2</sup> )	Nominal outer diameter (mm)	Tolerance (mm)
SI - (Incremental encoder + SinCos EnDat 2.1)	6 x 2 x 0.25 + 1 x 2 x 0.34 + 1 x 2 x 0.50 mm <sup>2</sup>	10.2	± 0.3
SR - (Resolver)	4 x (2 x 0.25) ST mm <sup>2</sup>	8.9	± 0.3
SS - (Sincos Hiperface Encoder)	4 x (2 x 0.15) + 1 x 2 x 0.50 mm <sup>2</sup>	7.3	± 0.3
SE - (Serial EnDat 2.2 only)	4 x (2 x 0.15) + 1 x 2 x 0.50 ST mm <sup>2</sup>	7.3	± 0.3

## EnDat 2.2 Hybrid cable (power and signal combined)

Phase and conductor size (current rating CEI EN 60204-1:2006-09 at 40 °C - installation method B2)	Construction cross section (mm <sup>2</sup> )	Nominal outer diameter (mm)	Tolerance (mm)
A - 1.5 mm <sup>2</sup> + 0.75 mm <sup>2</sup> (13.1 A)	4G1.5 + (2 x 0.75) ST+ (2 x AWG24) + 2x (2 x AWG28)	13.7	± 0.3
B - 2.5 mm <sup>2</sup> + 1 mm <sup>2</sup> (7.4 A)	4G2.5 + (2 x 0.75) ST+ (2 x AWG24) + 2x (2 x AWG28)	14.8	± 0.3
C - 4 mm <sup>2</sup> + 1 mm <sup>2</sup> (23 A)	4G4.0 + (2 x 1.0) ST+ (2 x AWG24) + 2x (2 x AWG28) / ST	16.1	± 0.3

## EnDat 3 Hybrid cable (power and signal combined)

Phase and conductor size (current rating CEI EN 60204-1:2006-09 at 40 °C - installation method B2)	Construction cross section (mm <sup>2</sup> )	Nominal outer diameter (mm)	Tolerance (mm)
A - 1.5 mm <sup>2</sup> + 0.75 mm <sup>2</sup> (3.1 A)	4G1.5 + (2 x 0.75) ST+ (2 x AWG22) ST/ST-PU	13.2	± 0.3
B - 2.5 mm <sup>2</sup> + 1 mm <sup>2</sup> (17.4 A)	4G2.5 + (2 x 1) ST+ (2 x AWG22) ST/ST-PU	14.2	± 0.3

ST = Static Screen

AWG = American Wire Gauge

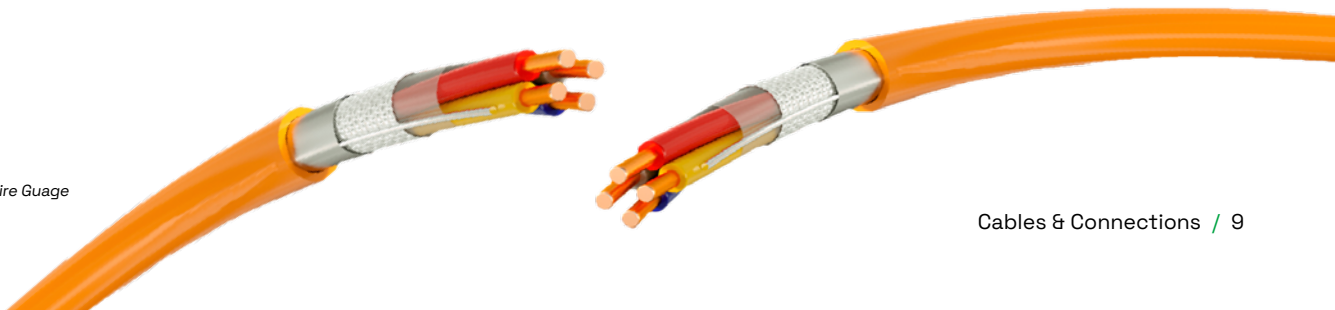

## Power plug - motor end

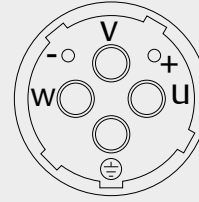
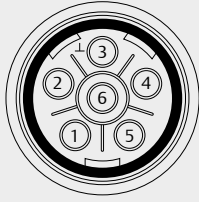

Size 1 Type connector			Size 1.5 Type connector		
	With brake	Without brake		With brake	Without brake
Pin	Function	Function	Pin	Function	Function
1	Phase U (R)	Phase U (R)	U	Phase U (R)	Phase U (R)
2	Phase V (S)	Phase V (S)	V	Phase V (S)	Phase V (S)
3	Ground	Ground	⊖	Ground	Ground
4	Phase W (T)	Phase W (T)	W	Phase W (T)	Phase W (T)
5	Brake		+	Brake	
6	Brake		-	Brake	
Shell	Screen	Screen	Shell	Screen	Screen

## Signal plug - motor end

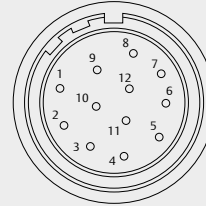
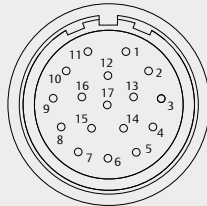

Pin	SI		SE	SR	SS
	Incremental encoder (CA, CT, CR, CN)	Sincos absolute encoders (EM, FM, EC, FC, EB, FB)*	Endat and BiSS-C encoders (EF, FF, EC, FC, EM, FM EG, FG, GB, HB, EN, FN, EZ, EH)	Resolver (AE, AR)	SICK SinCos Hiperface encoders (RA, TL, UL, SA)
Pin	Function	Function	Function	Function	Function
1	Thermistor	Thermistor	Thermistor	Excitation High	REF Cos
2	Thermistor	Thermistor	Thermistor	Excitation Low	+ Data
3		Screen (Optical only)	Screen (Optical only)	Cos High	- Data
4	S1			Cos Low	+ Cos
5	S1 Inverse			Sin High	+ Sin
6	S2			Sin Low	REF Sin
7	S2 Inverse			Thermistor	Thermistor
8	S3	+ Clock	+ Clock	Thermistor	Thermistor
9	S3 Inverse	- Clock	- Clock		Screen
10	Channel A	+ Cos			0 V
11	Index	+ Data	+ Data		-
12	Index Inverse	- Data	- Data		+ V
13	Channel A Inverse	- Cos			
14	Channel B	+ Sin			
15	Channel B Inverse	- Sin			
16	+ V	+ V	+ V		
17	0 Volts	0 V	0 V		
Body	Screen	Screen	Screen		Screen

\* legacy feedback options

## Hybrid plug (power & signal combined) - motor end

Size 1			Size 1.5		
Heidenhain EnDat only absolute encoders (EF, FF, EC, FC, EM, FM, EG, FG, GB, HB, EN, FN)			Heidenhain EnDat only absolute encoders (EF, FF, GB, HB)		
	With brake	Without brake		With brake	Without brake
Pin	Function	Function	Pin	Function	Function
1	+ V	+ V	1	+ V	+ V
2	0 V	0 V	2	0 V	0 V
3	+ Data	+ Data	3	+ Data	+ Data
4	- Data	- Data	4	- Data	- Data
5	+ Clock	+ Clock	5	+ Clock	+ Clock
6	- Clock	- Clock	6	- Clock	- Clock
7	- Brake		N	-	-
8	+ Brake		U	Phase U (R)	Phase U (R)
A	Phase U (R)	Phase U (R)	V	Phase V (S)	Phase V (S)
B	Phase V (S)	Phase V (S)	PE	Ground	Ground
C	Phase W (T)	Phase W (T)	W	Phase W (T)	Phase W (T)
D	-	-	+	Brake	
E	Ground	Ground	-	Brake	

Please note the thermistor is wired through the encoder for the power/signal combined.

## 2 Wire encoder hybrid plug - motor end

Size M23	
Heidenhain EnDat 3 only GF, EF	
Pin	Function
1	Phase U
2	PE
3	Phase W
4	Phase V
A	+Data
B	-Data
C	+Brake
D	-Brake

## 15 Way plug - drive end

Pin	SI		SE	SR	SS
	Incremental encoders (CA, CT, CR)	SinCos absolute encoders (EM, FM, EC, FC, EB, FB)	Endat and BiSS-C encoders (EF, FF, EM, FM, EC, FC, EG, FG, GB, HB, EN, FN, EZ, EH)	Resolvers (AE, AR)	SinCos Hiperface encoders (TL, UL, RA, SA)
Pin	Function	Function	Function	Function	Function
1	Channel A	+ Cos	+ Data	+ Cos	+ Cos
2	Channel A Inverse	- Cos	- Data	- Cos	REF Cos
3	Channel B	+ Sin	+ Clock	+ Sin	+ Sin
4	Channel B Inverse	-Sin	- Clock	- Sin	REF Sin
5	Index	+ Data		+ Excitation	+ Data
6	Index Inverse	- Data		- Excitation	- Data
7	S1				
8	S1 Inverse				
9	S2				
10	S2 Inverse				
11	S3	+ Clock			
12	S3 Inverse	- Clock			
13	+ V	+ V	+ V		+ V
14	0 V	0 V	0 V	Thermistor	0 V
15	Thermistor	Thermistor	Thermistor	Thermistor	Thermistor
Body	Screen	Screen	Screen	Screen	Screen

**Y-TEC signal / power plug - Motor end**

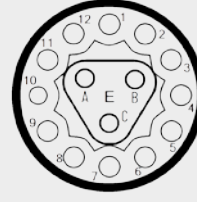
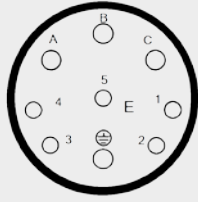

Power - Type T connector			Signal - Type T Connector (CT)	
Pin	With brake Function	Without brake Function	Pin	Function
A	Phase U	Phase U	1	Ground
B	Phase V	Phase V	2	Channel A
C	Phase W	Phase W	3	Channel A Inverse
1	Thermistor +	Thermistor +	4	Channel B
2	Thermistor -	Thermistor -	5	Channel B Inverse
3	+ V		6	+ V
4	0 Volts		7	S1
⊕	Ground	Ground	8	S2
			9	S3
			10	S1 Inverse
			11	S2 Inverse
			12	S3 Inverse
			A	Index
			B	Index Inverse
			C	-

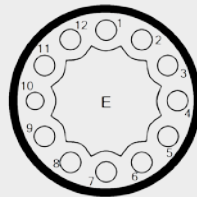
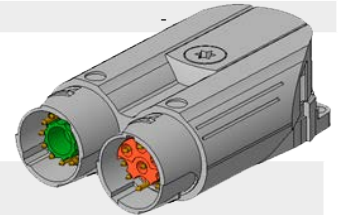

Signal - Type T Connector			
Pin	EnDat only encoders (EG, FG)	SICK Sincos Hiperface encoder (TL, UL)	Resolver (SR)
Pin	Function	Function	Function
1	+ V	+ V	-
2	+ Data	+ Data	-
3	- Data	- Data	-
4	+ Clock	-	-
5	- Clock	-	-
6	-	-	Excitation low
7	0 V	0 V	-
8	-	+ Sin	Sin high
9	-	REF Sin	Sin low
10	-	+ Cos	Cos high
11	-	REF Cos	Cos low
12	-	-	Excitation high

## 8 Way power plug - motor end

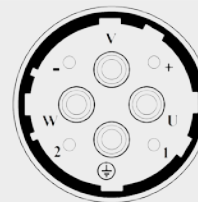
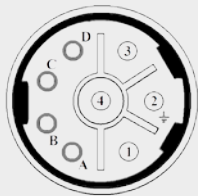

Size 1 - Type R Connector			Size 1.5 - Type Z Connector		
Pin	With brake Function	Without brake Function	Pin	With brake Function	Without brake Function
1	Phase U (R)	Phase U (R)	U	Phase U (R)	Phase U (R)
2	Ground	Ground	V	Phase V (S)	Phase V (S)
3	Phase W (T)	Phase W (T)	⊖	Ground	Ground
4	Phase V (S)	Phase V (S)	W	Phase W (T)	Phase W (T)
A	Thermistor	Thermistor	+	Brake	
B	Thermistor	Thermistor	-	Brake	
C	Brake		1	Thermistor	Thermistor
D	Brake		2	Thermistor	Thermistor
Shell	Screen	Screen	Shell	Screen	Screen

## Perfect combinations



### Digitax HD

Optimised for high-dynamic applications, Digitax HD provides the flexibility of both standalone and modular configurations. The drive offers full servo control plus open loop permanent magnet and induction motor control across four functionality levels: EtherCAT, MCI machine control, multiprotocol Ethernet and the flexible Base drive.

*For motors below 16 A continuous stall current.*



### Unidrive M700

Unidrive M700 series provides high performance motor control and ultimate control flexibility in order to satisfy the requirements of machine builders and high specification industrial and hoisting applications.

*For motors above 16 A continuous stall current.*



### Unimotor hd

Unimotor hd is Nidec Drives' high dynamic brushless AC servo motor range. With high peak torque, low inertia and the most compact dimensions, Unimotor hd is optimised for applications requiring rapid acceleration and deceleration.



# Cable diameter selection

Cable and connector required according to motor size

## 3 Phase VPWM drives 200-240 V<sub>rms</sub> - Unimotor fm

Frame length	075E3				095E3					115E3				
	A	B	C	D	A	B	C	D	E	A	B	C	D	E
Speed 2,000 (rpm)														
Cross section (mm <sup>2</sup> )	1.0	1.0	1.0	1.0	1.0	1.0	1.0	1.0	1.0	1.0	1.0	1.0	1.0	2.5
Recommended connector size	1	1	1	1	1	1	1	1	1	1	1	1	1	1
Speed 3,000 (rpm)														
Cross section (mm <sup>2</sup> )	1.0	1.0	1.0	1.0	1.0	1.0	1.0	1.0	1.0	1.0	1.0	2.5	2.5	2.5
Recommended connector size	1	1	1	1	1	1	1	1	1	1	1	1	1	M6
Speed 4,000 (rpm)														
Cross section (mm <sup>2</sup> )	1.0	1.0	1.0	1.0	1.0	1.0	1.0	2.5	2.5	1.0	2.5	2.5	2.5	4.0
Recommended connector size	1	1	1	1	1	1	1	1	1	1	1	1	1	M6
Speed 6,000 (rpm)														
Cross section (mm <sup>2</sup> )	1.0	1.0	1.0	1.0	1.0	1.0	2.5	•	•	1.0	2.5	•	•	•
Recommended connector size	1	1	1	1	1	1	1	•	•	1	1	•	•	•

142E3					190E3								Motor Frame Size (mm)		
A	B	C	D	E	A	B	C	D	E	F	G	H	Frame length		
Speed 2,000 (rpm)															
1.0	1.0	2.5	2.5	4.0	1.0	2.5	6.0	10.0	10.0	16.0	16.0	25.0	Cross section (mm <sup>2</sup> )		
1	1	1	1	1.5	1.5	1.5	1.5	1.5	1.5	M6			Recommended connector size		
Speed 3,000 (rpm)															
1.0	2.5	2.5	4.0	6.0	2.5	6.0	10.0	16.0	25.0	25.0	25.0	25.0	Cross section (mm <sup>2</sup> )		
1	1	1	1.5	1.5	1.5	1.5	1.5	M6			M6			Recommended connector size	
Speed 4,000 (rpm)															
1.0	2.5	4.0	6.0	10.0	2.5	10.0	16.0	25.0	•	•	•	•	Cross section (mm <sup>2</sup> )		
1	1	1.5	1.5	1.5	1.5	1.5	M6		•	•	•	•	Recommended connector size		
Speed 6,000 (rpm)															
2.5	•	•	•	•	•	•	•	•	•	•	•	•	Cross section (mm <sup>2</sup> )		
1	•	•	•	•	•	•	•	•	•	•	•	•	Recommended connector size		

## 3 Phase VPWM drives 200-240 V<sub>rms</sub> - Unimotor hd

Motor Frame Size (mm)	060ED			067ED				089ED				115ED				142ED					190ED						
	A	B	C	A	B	C	D	A	B	C	D	A	B	C	D	A	B	C	D	E	A	B	C	D	E	F	
Speed 2,000 (rpm)																											
Cross section (mm <sup>2</sup> )	•	•	•	•	•	•	•	•	•	•	•	•	1.0	2.5	2.5	2.5	2.5	4.0	4.0	6.0	•	•	4.0	4.0	•	10.0	
Recommended connector size	•	•	•	•	•	•	•	•	•	•	•	•	1	1	1	1	1	1.5	1.5	1.5	•	•	1.5	1.5	•	1.5	
Speed 3,000 (rpm)																											
Cross section (mm <sup>2</sup> )	•	•	•	1.0	1.0	1.0	1.0	1.0	1.0	1.0	•	2.5	2.5	2.5	•	2.5	4.0	6.0	10.0	•	•	•	10.0	•	•	•	
Recommended connector size	•	•	•	1	1	1	1	1	1	1	•	1	1	1	•	1	1.5	1.5	1.5	•	•	•	1.5	•	•	•	
Speed 4,000 (rpm)																											
Cross section (mm <sup>2</sup> )	•	•	•	•	•	•	•	1.0	1.0	2.5	•	•	•	•	•	•	•	6.0	•	•	•	•	•	10.0	•	•	•
Recommended connector size	•	•	•	•	•	•	•	1	1	1	•	•	•	•	•	•	•	1.5	•	•	•	•	•	1.5	•	•	•
Speed 6,000 (rpm)																											
Cross section (mm <sup>2</sup> )	1.0	1.0	1.0	1.0	1.0	1.0	1.0	1.0	2.5	4.0	•	•	•	•	•	•	•	•	•	•	•	10.0	•	•	•	•	•
Recommended connector size	1	1	1	1	1	1	1	1	1	1	•	•	•	•	•	•	•	•	•	•	•	1.5	•	•	•	•	•

- • frame size not available
- The information contained in this specification is for guidance only and does not form part of any contract.
- Nidec Drives have an ongoing process of development and reserves the right to change the specification without notice.

### 3 Phase VPWM drives 380-480 V<sub>rms</sub> - Unimotor fm

Motor Frame Size (mm)	075U3				095U3					115U3				
Frame length	A	B	C	D	A	B	C	D	E	A	B	C	D	E
Speed 2,000 (rpm)														
Cross section (mm <sup>2</sup> )	1.0	1.0	1.0	1.0	1.0	1.0	1.0	1.0	1.0	1.0	1.0	1.0	1.0	1.0
Recommended connector size	1	1	1	1	1	1	1	1	1	1	1	1	1	1
Speed 3,000 (rpm)														
Cross section (mm <sup>2</sup> )	1.0	1.0	1.0	1.0	1.0	1.0	1.0	1.0	1.0	1.0	1.0	1.0	1.0	2.5
Recommended connector size	1	1	1	1	1	1	1	1	1	1	1	1	1	1
Speed 4,000 (rpm)														
Cross section (mm <sup>2</sup> )	1.0	1.0	1.0	1.0	1.0	1.0	1.0	1.0	1.0	1.0	1.0	1.0	2.5	2.5
Recommended connector size	1	1	1	1	1	1	1	1	1	1	1	1	1	1
Speed 6,000 (rpm)														
Cross section (mm <sup>2</sup> )	1.0	1.0	1.0	1.0	1.0	1.0	1.0	•	•	1.0	1.0	•	•	•
Recommended connector size	1	1	1	1	1	1	1	•	•	1	1	•	•	•

142U3					190U3								250U3		
A	B	C	D	E	A	B	C	D	E	F	G	H	D	E	F
Speed 2,000 (rpm)													Speed 1,000 (rpm)		
1.0	1.0	1.0	1.0	2.5	1.0	1.0	2.5	4.0	4.0	6.0	10.0	10.0	4.0	4.0	6.0
1	1	1	1	1	1.5	1.5	1.5	1.5	1.5	1.5	1.5	1.5	1.5	1.5	1.5
Speed 3,000 (rpm)													Speed 1,500 (rpm)		
1.0	1.0	1.0	2.5	2.5	1.0	2.5	4.0	6.0	10.0	10.0	16.0	16.0	6.0	10.0	10.0
1	1	1	1	1	1.5	1.5	1.5	1.5	1.5	1.5	M6		1.5	1.5	1.5
Speed 4,000 (rpm)													Speed 2,000 (rpm)		
1.0	1.0	2.5	4.0	4.0	1.0	4.0	6.0	10.0	•	•	•	•	10.0	16.0	16.0
1	1	1	1.5	1.5	1.5	1.5	1.5	1.5	•	•	•	•	1.5	M8	
Speed 6,000 (rpm)													Speed 2,500 (rpm)		
1.0	2.5	•	•	•	•	•	•	•	•	•	•	•	16.0	25.0	25.0
1	1	•	•	•	•	•	•	•	•	•	•	•		M8	

### 3 Phase VPWM drives 380-480 V<sub>rms</sub> - Unimotor hd

Motor Frame Size (mm)	060UD				067UD				089UD				115UD				142UD					190UD											
Frame length	A	B	C	D	A	B	C	D	A	B	C	D	A	B	C	D	A	B	C	D	E	A	B	C	D	E	F						
Speed 2,000 (rpm)																																	
Cross section (mm <sup>2</sup> )	•	•	•	•	•	•	•	•	•	•	•	•	•	•	•	•	1.0	1.0	1.0	1.0	1.0	1.0	1.0	1.0	2.5	2.5	2.5	•	•	4.0	4.0	•	6.0
Recommended connector size	•	•	•	•	•	•	•	•	•	•	•	•	•	•	•	•	1	1	1	1	1	1	1	1	1	1	1	•	•	1.5	1.5	•	1.5
Speed 3,000 (rpm)																																	
Cross section (mm <sup>2</sup> )	•	•	•	1.0	1.0	1.0	1.0	1.0	1.0	1.0	1.0	1.0	1.0	1.0	2.5	2.5	2.5	2.5	4.0	6.0	•	2.5	2.5	2.5	2.5	2.5	6.0	•	2.5	2.5	2.5	2.5	6.0
Recommended connector size	•	•	•	1	1	1	1	1	1	1	1	1	1	1	1	1	1	1	1	1	1	1	1	1	1	1.5	1.5	•	1.5	1.5	1.5	1.5	1.5
Speed 4,000 (rpm)																																	
Cross section (mm <sup>2</sup> )	•	•	•	•	•	•	•	1.0	1.0	1.0	•	1.0	1.0	1.0	•	2.5	4.0	4.0	•	2.5	2.5	4.0	6.0	10.0	10.0	•	2.5	2.5	4.0	6.0	10.0	10.0	
Recommended connector size	•	•	•	•	•	•	•	1	1	1	•	1	1	1	•	1	1.5	1.5	•	1.5	1.5	1.5	1.5	1.5	1.5	1.5	•	1.5	1.5	1.5	1.5	1.5	
Speed 6,000 (rpm)																																	
Cross section (mm <sup>2</sup> )	1.0	1.0	1.0	1.0	1.0	1.0	1.0	1.0	1.0	1.0	•	1.0	1.0	•	•	•	2.5	•	•	•	4.0	4.0	•	•	•	•	4.0	4.0	•	•	•	•	
Recommended connector size	1	1	1	1	1	1	1	1	1	1	•	1	1	•	•	•	1.5	•	•	•	1.5	1.5	•	•	•	•	1.5	1.5	•	•	•	•	

- The recommended connector has been selected using the connector manufacturer's de-rating values applied to a motor at full operational temperature.
- M6/M8 refers to ring terminal sizes on hybrid box.

### 3 Phase VPWM drives 380 - 480 V<sub>rms</sub> - Unimotor fm fan blown

Motor Frame Size (mm)	095U5		115U5		142U5		190U5	
Frame length	D	E	D	E	D	E	G	H
Speed 2,000 (rpm)								
Cross section (mm <sup>2</sup> )	•	•	•	•	•	•	10.0	16.0
Recommended connector size	•	•	•	•	•	•	1.5	M6
Speed 3,000 (rpm)								
Cross section (mm <sup>2</sup> )	1.0	1.0	2.5	2.5	2.5	4.0	16.0	25.0
Recommended connector size	1	1	1	1	1.5	1.5	M6	M8
Speed 4,000 (rpm)								
Cross section (mm <sup>2</sup> )	1.0	1.0	2.5	4.0	4.0	6.0	25.0	25.0
Recommended connector size	1	1	1	Hybrid box	1.5	1.5	M8	M8
Speed 6,000 (rpm)								
Cross section (mm <sup>2</sup> )	2.5	2.5	4.0	6.0	10.0	16.0	•	•
Recommended connector size	1	1	M6	M6	1.5	M6	•	•

## Hybrid box connections

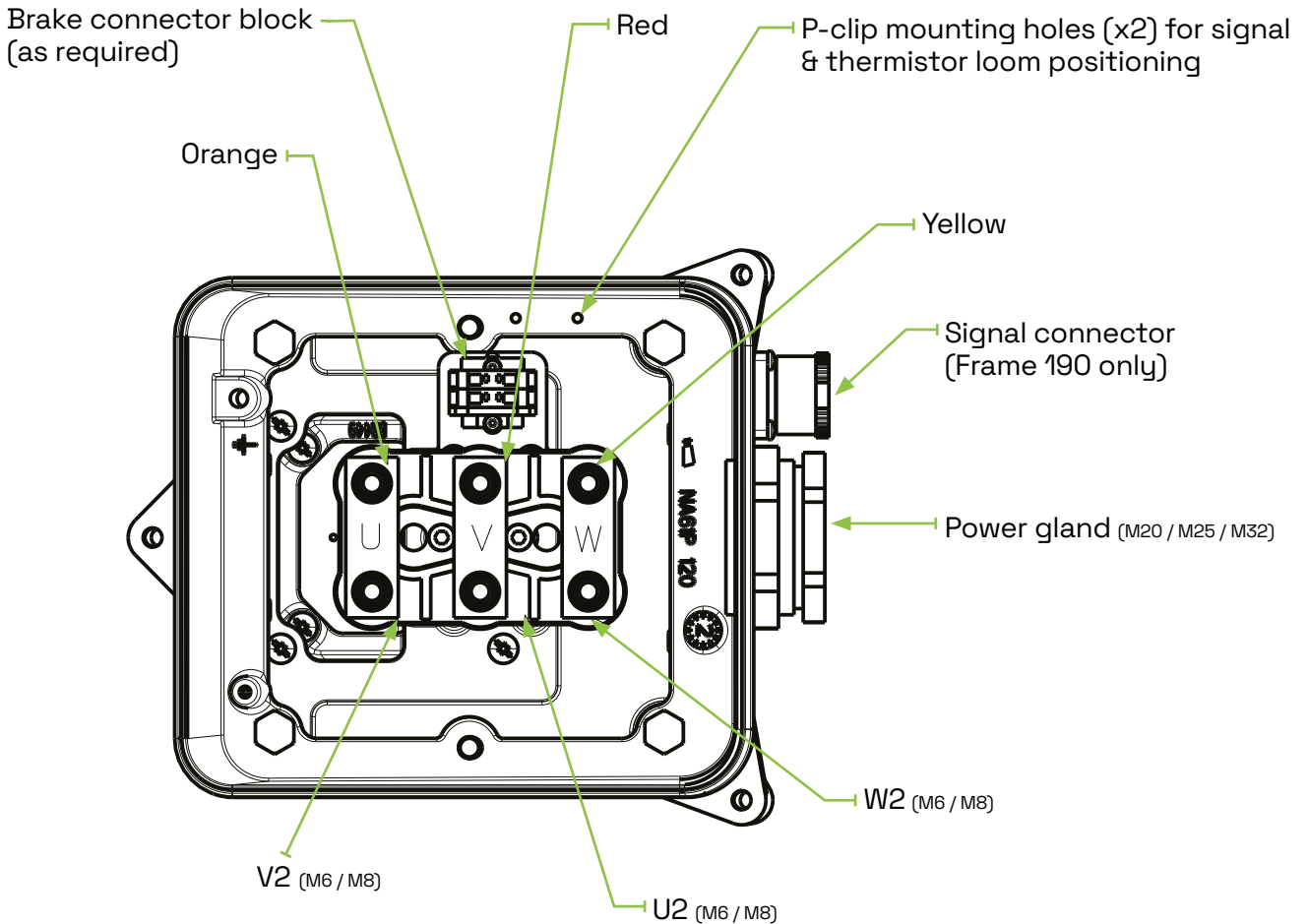

# Fan box connections

Function	Wire colour	Socket
N/C		1
N/C		2
N/C		3
Neutral	Blue	4
Live	Brown	5
Earth	Green	6

Unimotor hd frame size	Clearance distance behind fan box mm	Voltage Vac	Fan current rating A
115	40	230	0.08
142	50	230	0.07
190	60	230	0.13

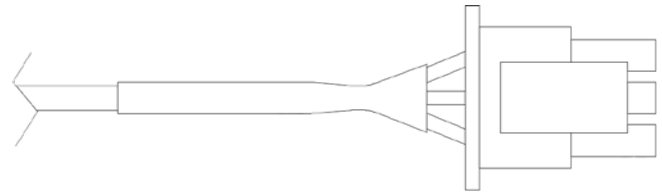
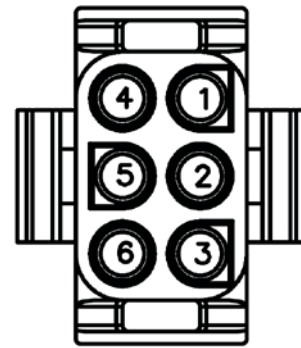

# Terminal box - optional

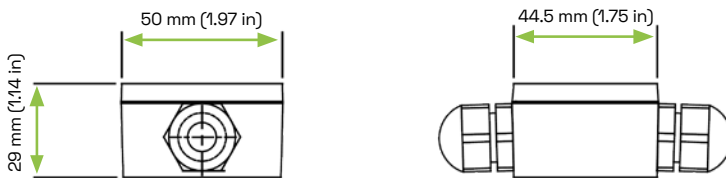

Item	Part number	Description	Qty
1	IM/0078/MC	Connector box + Earth screw	1
2	754.335.2	Nylon cable gland	2
3	755.407.9	Terminal block (2-way)	1
4	615.777.4	Screw M2.5 x 16 CSK posi BZP	1
5	615.975.3	M2.5 full BZP nut	1
6	752-424.2	Insulated ring terminal	1
7	751.974.5	Wire marker '1'	1
8	751.973.7	Wire marker '2'	1

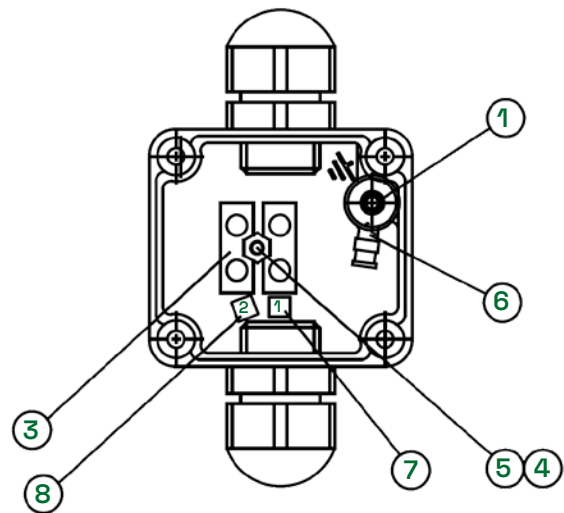

# Maximum cable length

The maximum cable length is restricted by the effect of the voltage drop on the power supply to the encoder.

## Maximum recommended length

Cable Types	Maximum cable length										
	Resolver		Renco	CT	Sick		Heidenhain				
SIBA - SC EnDat			CR 50 m	CT 50 m	CA 50 m		EB/FB 100 m	EM/FM 100 m	EC/FC 100 m		
SEBE - Serial EnDat Only							EG/FG 100 m	GB/HB 100 m	EN/FN 100 m	EC/FC 100 m	EM/FM 100 m
SSBA - SinCos SICK Hiperface					TL/UL 100 m	RA/SA 100 m					
SRBA - Resolver	AE 100 m	AR 100 m									
HYB - Power + Signal Combined							EG/FG 100 m	EF/FF 100 m	EN/FN 100 m	GB/HB 100 m	
HQB - Power + Signal Combined							EE/FE 50 m	EP/FP 50 m			



For Digitax HD maximum cable length is 50 m.



**Nidec**

Autom

Innovati  
environn  
comfort

# The world's leading global manufacturer of electric motors and controls

Nidec, the world's largest motor brand.

**Nidec is in everything, everywhere.**

If you drive a car, wash your clothes, watch movies or talk on a smartphone, you're using Nidec technology. Almost anything that spins and moves, no matter how big or small, does so thanks to a Nidec product.

Our shared values of passion, enthusiasm and tenacity guide us on our collective journey to be the best.



## Appliance, commercial & industrial motors

Energy efficient motor and drive technology for commercial, industrial, and home appliances

## Automotive

Helping to help improve safety, environmental protection and performance required for automobiles



## Small precision motors

DC motors for all industries and applications



## Motion & Energy

High-performance motors, drives, generators & energy management solutions for renewables, automation, infrastructure, and electric vehicles

## Machinery

Machines, factory automation equipment, measuring, and testing devices



Connect with us



[www.drivesfromnidec.com](http://www.drivesfromnidec.com)

©2026 Nidec Control Techniques Limited. The information contained in this brochure is for guidance only and does not form part of any contract. The accuracy cannot be guaranteed as Nidec Control Techniques Ltd have an ongoing process of development and reserve the right to change the specification of their products without notice.

Nidec Control Techniques Limited. Registered Office: The Gro, Newtown, Powys SY16 3BE.

Registered in England and Wales. Company Reg. No. 01236886.

