

Unidrive M600-M70X, F300, H300, E200 & E300 Size 5 DC Bus Paralleling Installation Sheet

1 Safety information



Stored charge

The drive contains capacitors that remain charged to a potentially lethal voltage after the AC supply has been disconnected. If the drive has been energized, the AC supply must be isolated for at least ten minutes before work may continue. Refer to section 3.1 Safety information in the *User Guide*.



Isolation device

The AC / DC supply must be disconnected from the drive using an approved isolation device before any cover is removed from the drive or before any servicing work is performed.



Follow the instructions

The mechanical and electrical installation instructions must be adhered to. Any questions should be referred to the supplier of the equipment. It is the responsibility of the owner or user to ensure that the installation of the drive and any external option unit, and the way in which they are operated and maintained, comply with the requirements of the Health and Safety at Work Act in the United Kingdom or applicable legislation and regulations and codes of practice in the country in which the equipment is used.

2 Introduction

This document covers DC bus paralleling instructions for Unidrive M600 / M700, F300, H300, E200 & E300 size 5 drives. The Unidrive M terminal and enclosure design enables the DC bus of a number of drives to be connected together using a pre-formed busbar kit (CT part number: 3470-0068-01).

The following instructions describe the DC bus paralleling of two Unidrive M size 5 drives. Throughout this sheet, the drives are labelled 1 and 2 to aid identification. To increase the total number of drives connected to the DC bus, repeat the following instructions.

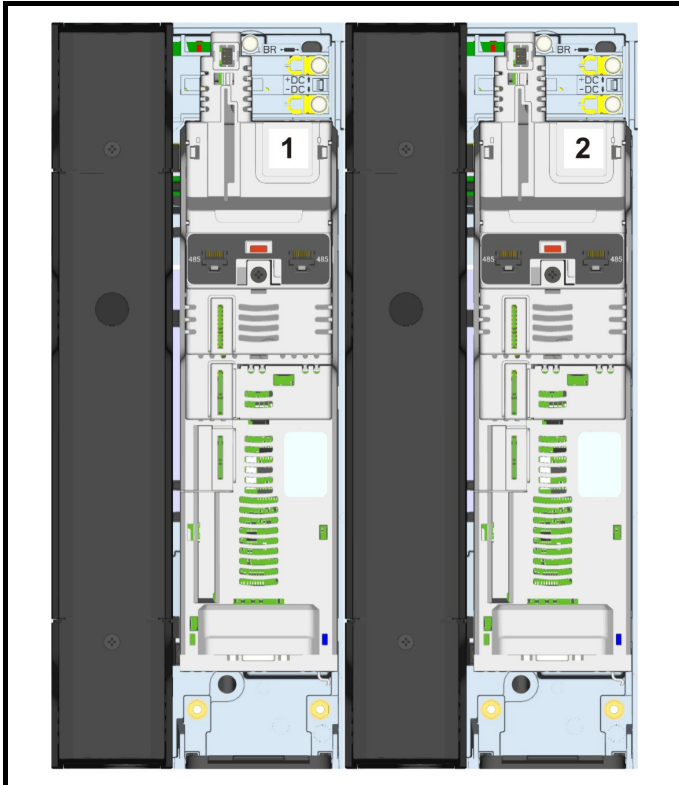

NOTE

There are limitations to the combinations of the drives which can be used in this configuration. For application data, contact the supplier of the drive.

Contents of the kit bag (CT part number: 3470-0068-01)

The following items are supplied in the kit bag:

Item	Quantity
DC busbar	x 2
M4 Screw	x 2

3 Instructions

STEP 1 - Drive 1 and 2

Figure 1-1 Removing the AC, DC and power terminal covers

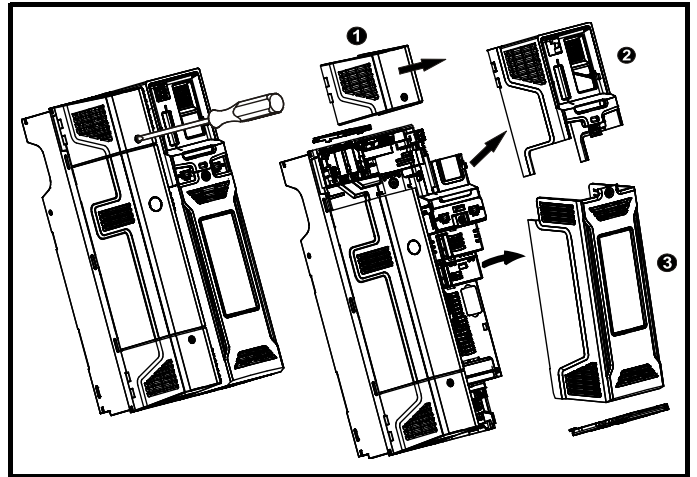

On drive 1, remove all terminal covers except the top left hand cover (1).

On drive 2, remove all terminal covers as shown in Figure 1-1 above.

To remove the terminal covers, undo the screw (1) and remove the covers as shown in Figure 1-1.

The AC terminal cover (1), must be removed before the DC terminal cover (2) can be removed.

When replacing the terminal covers, the screws should be tightened to a maximum torque of 1 N m (9 lb in).



0478-0053-02

STEP 2 - Drive 1

Figure 1-2 Removing the M4 screws from the DC busbars

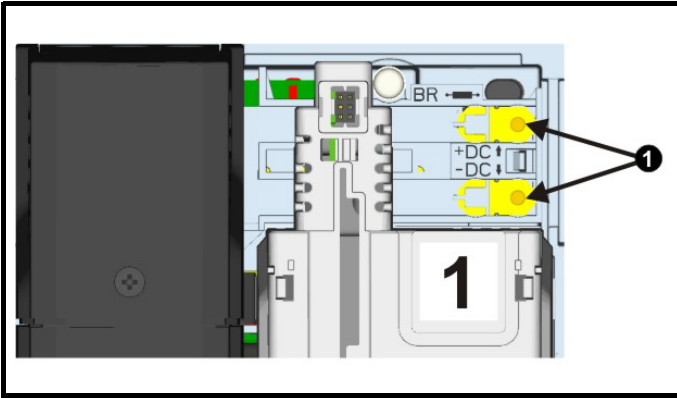

Remove the two M4 screws (1) located on the DC busbars.

STEP 3 - Drive 2

Breaking out the DC barrier tabs on the second drive

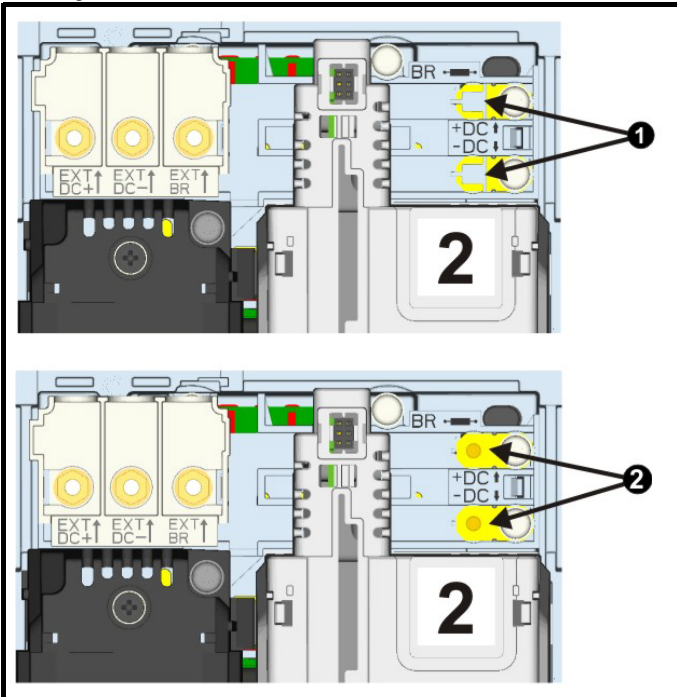

Remove the breakout tabs on the DC barrier by inserting a screwdriver under the tabs and lifting upwards (1). This will reveal the threaded mounting holes for the busbars as shown in (2).

STEP 4 - Drive 2

Figure 1-3 Removing the DC terminal block

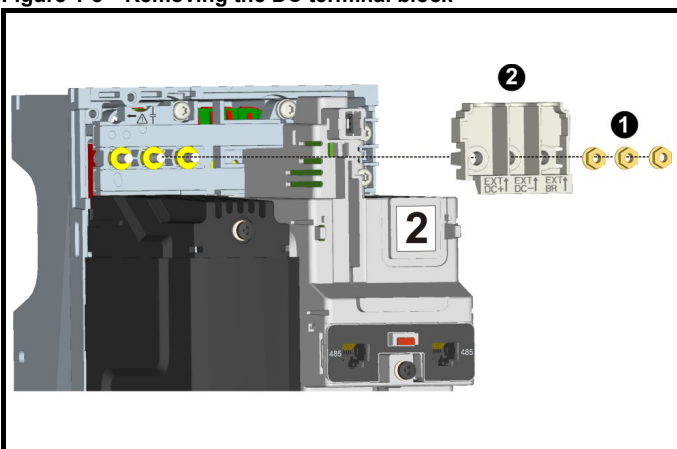

Remove the three M5 terminal nuts (1) and terminal block (2).

STEP 5 - Drive 1 and 2

Figure 1-4 Breaking out the tabs

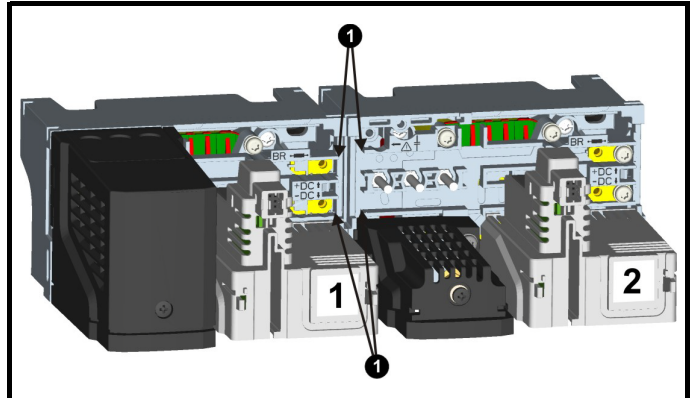

Using a pair of long nose pliers, break out the two tabs (1) on the DC barriers on the right hand side of drive 1, plus the two tabs (1) on the left hand side of drive 2 as shown in Figure 1-4. This will permit the installation of the DC busbars in the next step.

DO NOT break out the tabs on the outer ends of the drives, as this is not a requirement when installing the parallel busbars, and should therefore remain intact.

STEP 6 - Drive 1 and 2

Figure 1-5 Installing the DC - busbar

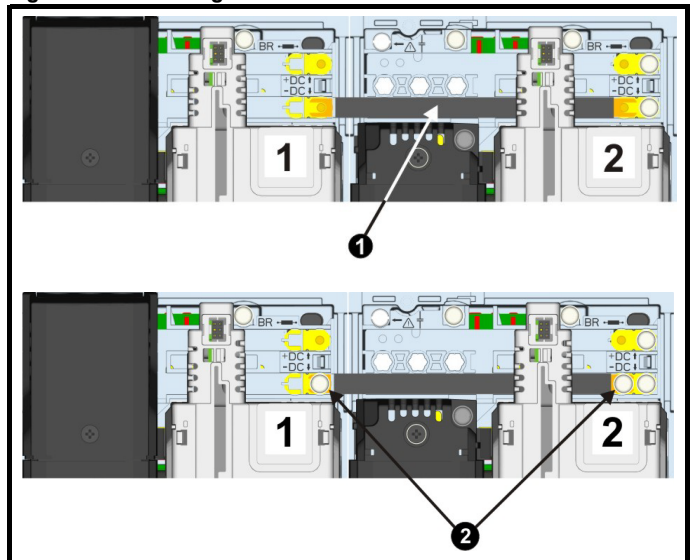

Locate the DC- busbar by passing it behind the control pod cover on the second drive and position it so that the fixing holes are over the threaded terminals on the DC- busbar mounting holes (1).

Alternatively if space permits, the minus DC - busbar can also be located by sliding it towards the left, from the right hand side of the second drive, or simply dropping it in place, passing over the DC barriers from the top.

Replace the two M4 screws in the DC- busbar as shown in Figure 1-5 (2). The screws should be tightened to maximum torque of 2.0 N m (18 lb in).



0478-0053-02

Figure 1-6 Installing the DC + busbar

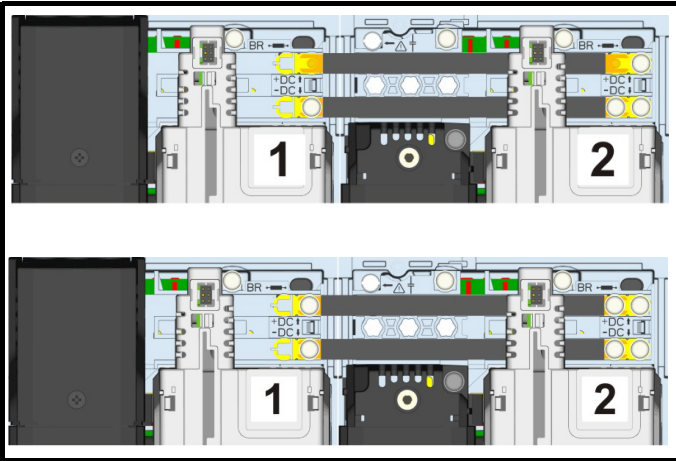

To install the DC+ busbar, follow the instructions given previously under Figure 1-5 relating to the installation of the DC- busbar.

Also remember to tighten the two M4 screws on the DC + busbar. The screws should be tightened to maximum torque of 2.0 N m (18 lb in).

STEP 7 Replacing DC terminal block

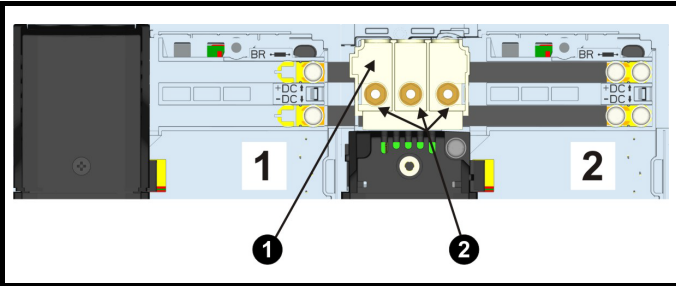

Reassemble the External DC terminal block (1) after installing the + and - DC busbar connections.

Replace the three washers and M4 combi nuts (2). Tighten to a maximum torque of 2.0 N m (18 lb in).

STEP 8 - Drive 1 and 2

Figure 1-7 Removing the break outs on the top left hand cover and DC terminal cover

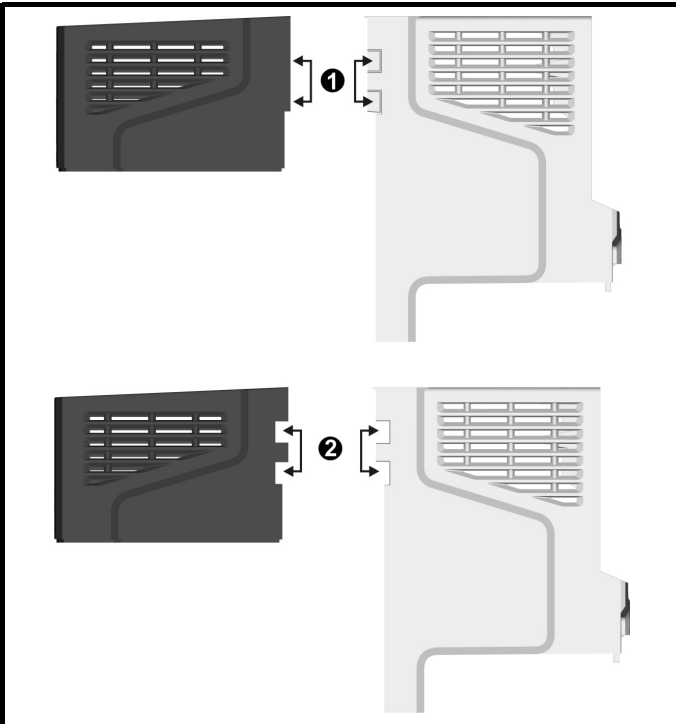

Using long nose pliers, break off the two pairs of breakout tabs on the top left hand cover, and the DC cover as shown in (1). This allows the installation of the two busbars between the two drives when the covers are replaced (2).

DO NOT break off the tabs on the outer sides of the covers, as this is not a requirement when installing the busbars.

STEP 9 - Drive 1 and 2 replacing the DC, AC and power covers

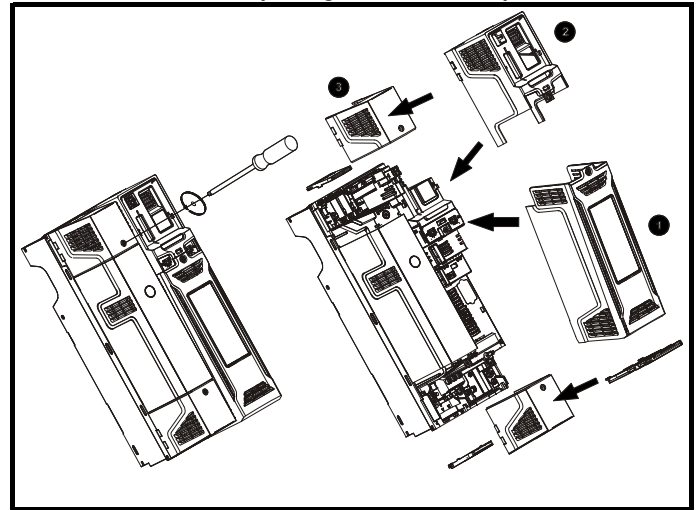

- Replace the DC cover (2)
- Replace the AC cover (1) and secure using the screw provided
- Replace the top left hand cover (3) and secure using the screw provided

When replacing terminal covers, the maximum torque required is 1 N m (9 lb in).

