

# Unidrive M200 to M702, F300, H300, E200 & E300 Size 5 UL Conduit Box Installation Sheet

## 1 Safety information



### Follow the instructions

The mechanical and electrical installation instructions must be adhered to. Any questions or doubt should be referred to the supplier of the equipment. It is the responsibility of the owner or user to ensure that the installation of the drive and any external option unit, and the way in which they are operated and maintained, comply with any applicable legislation, regulation, and code, of practice in the country in which the equipment is used.



### Competence of the installer

The drive must be installed by qualified personnel who are familiar with the requirements for safety and EMC. The installer is responsible for ensuring that the end product or system complies with all the relevant laws in the country where it is to be used.

## 2 Introduction



This document covers the UL conduit box mounting instructions for Unidrive M200 to M702, F300, H300, E200 & E300 frame size 5 drives.

When fitted, the drive meets the requirement for Type 1 protection according to UL50 and UL50E.

Type 1 enclosures are intended for indoor use only. They provide a degree of protection to personnel against incidental contact with the enclosed equipment and a degree of protection against falling debris.

The following items are supplied in the kit:

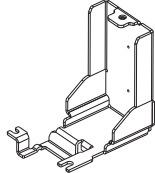
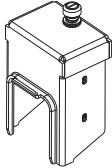
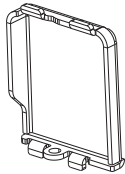
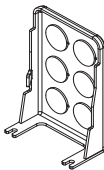
Table 2-1 Contents of the kit (CT part number: 3470-0120)

Description	Image	Qty
AC / motor power conduit box		x 1
AC / motor power conduit cover		x 1
DC power cover plate		x 1
Control conduit plate		x 1
M4 x 10 torx taptite screw		x 1
UL conduit box installation sheet		x 1

This conduit kit **must not** be used in applications that require DC power connections. Use conduit kit (3470-0069) for applications that require connections to the DC power terminals.

The installed conduit kit does not change the width or depth of the drive. However, this conduit kit will add 43 mm (1.7 in) to the height of the drive.

Table 2-2 shows the combined drive and conduit box dimensions.

Table 2-2 Dimensions

Frame size	H		W		D	
	mm	in	mm	in	mm	in
5	408	16.1	143	5.6	200	7.9

## 3 Installation



### Stored charge

The drive contains capacitors that remain charged to a potentially lethal voltage after the AC and / or DC power supply has been disconnected. If the drive has been energized, the power supply must be isolated at least ten minutes before work may continue.

Normally, the capacitors are discharged by an internal resistor. Under certain, unusual fault conditions, it is possible that the capacitors may fail to discharge, or be prevented from being discharged by a voltage applied to the output terminals. If the drive has failed in a manner that causes the display to go blank immediately, it is possible the capacitors will not be discharged. In this case, consult Control Techniques or their authorized distributor.

Figure 3-1 Removing the drive terminal covers

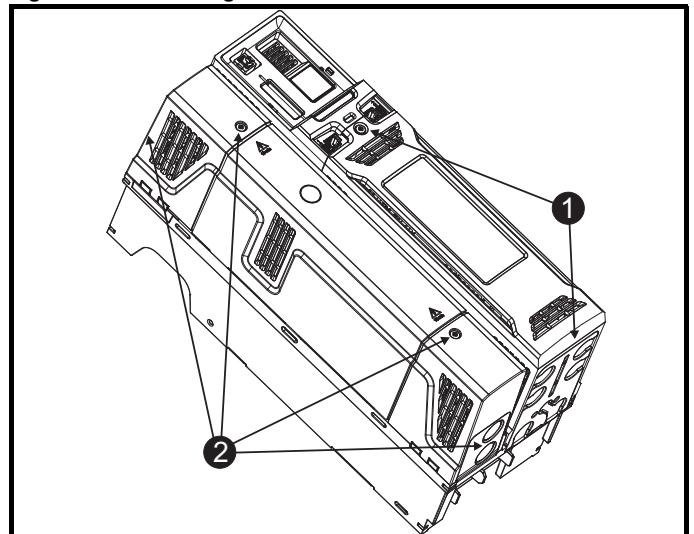

- Remove the control pod cover and the control finger guard (1).
- Remove the drive terminal covers and the power terminal finger guards (2).
- Unscrew the two M5 ground nuts and the two M4 ground nuts from the bottom drive terminal area.



0478-0365-03

Figure 3-2 Installation of AC / motor conduit connections

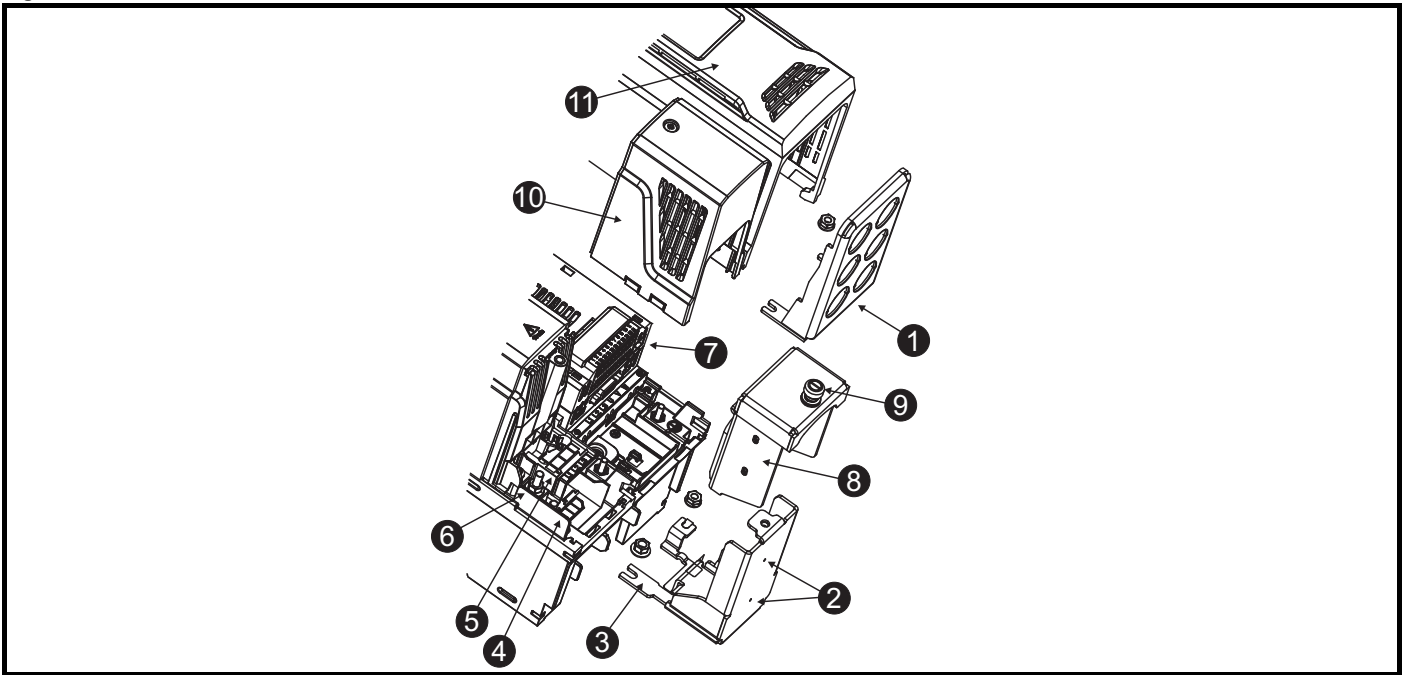

- Remove the necessary knockouts on the control conduit plate (1) and then attach to the drive using the two M4 nuts. Note that the AC / motor power conduit box will also need to be secured by the center M4 nut. Recommended torque for the M4 nut is 1.5 N m (13 lb in) (maximum torque is 2.5 N m (22 lb in)).
- Using the two pilot holes provided on the bottom of the conduit box (2), drill holes for appropriately sized conduit fittings.
- Attach the AC / motor power conduit box (3) onto the drive and fasten with the M4 nut and the M5 nut. Recommended torque for the M5 nut is 2 N m (18 lb in) (maximum torque is 5 N m (44 lb in)).
- Attach conduit fittings to the AC / motor power conduit box (2) and to the control conduit plate (1); run conduit to the drive. Supply cables, motor cables, and control wires must be run in separate conduits.
- Run the motor cables (U, V & W) and motor ground wire through the conduit. Connect the wires to the motor connector (U,V,W) (4). Recommended torque for screw terminals is 1.5 N m (13 lb in) (max. torque is 1.8 N m (16 lb in)). Insert motor connector (U,V,W) into the drive.
- Run the supply cables (L1, L2 & L3) and supply ground wire through the conduit. Connect the wires to the power connector (L1,L2,L3) (5). Recommended torque for screw terminals is 1.5 N m (13 lb in) (max. torque is 1.8 N m (16 lb in)). Insert power connector (L1,L2,L3) into the drive.
- Fasten M5 ring terminals, suitable for the wire size, to the supply ground and motor ground wires. Connect the ground wires to the screw stud (6) using the M5 nut. Recommended torque is 2 N m (18 lb in) (maximum torque is 5 N m (44 lb in)).
- Run the control cables through the conduit. Connect the control cables to the control connector as required (7). Maximum recommended torque for M200 to M400 control terminals is 0.2 N m (2 lb in); M600 to M702 control terminals is 0.5 N m (4.3 lb in).
- Guide the conduit cover over the AC / motor power conduit box (8). Tighten the PEM screw (9). Recommended torque is 2 N m (18 lb in) (maximum torque is 3 N m (26 lb in)).
- Replace the drive terminal cover (10) and the control pod cover (11). Recommended torque for the cover screw is 1 N m (9 lb in) (maximum torque is 2 N m (18 lb in)).

Figure 3-3 Installation of DC cover plate

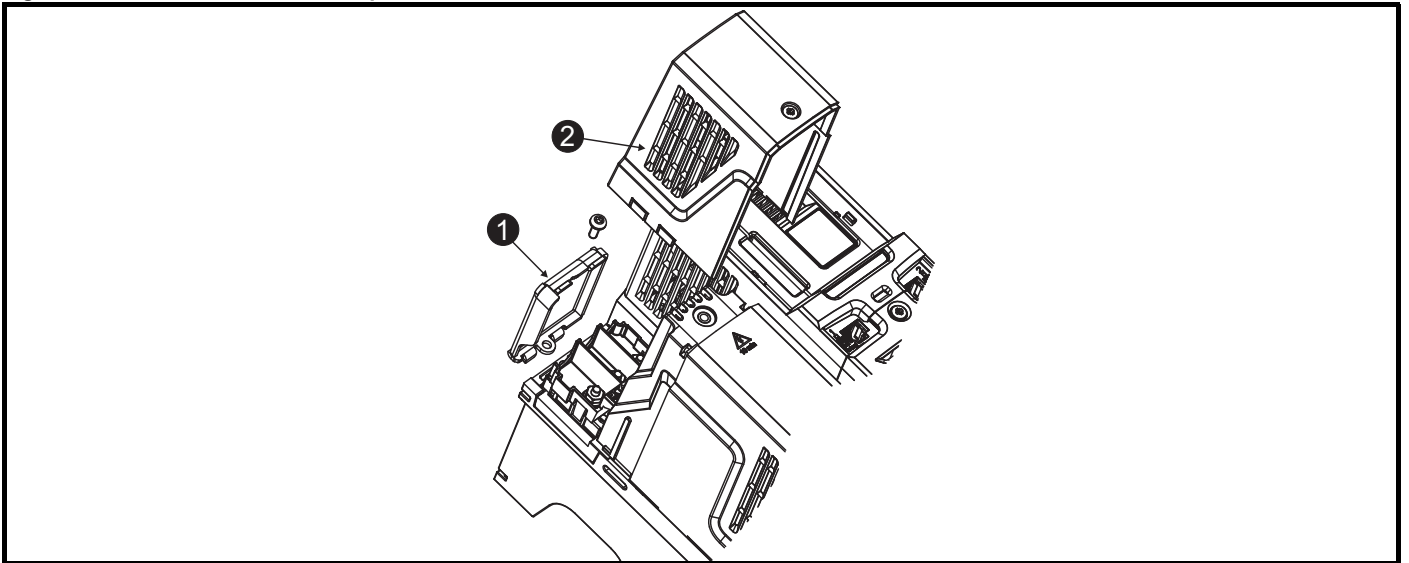

- Insert the DC power cover plate (1) and fasten with the M4 x 10 screw. Recommended torque for the screw is 2 N m (18 lb in) (maximum torque is 3 N m (26 lb in)).
- Replace the DC terminal cover (2). Recommended torque for the cover screw is 1 N m (9 lb in) (maximum torque is 2 N m (18 lb in)).

